

INSTRUCTIONS FOR OPERATING

The K9 and K9A

Cutawl

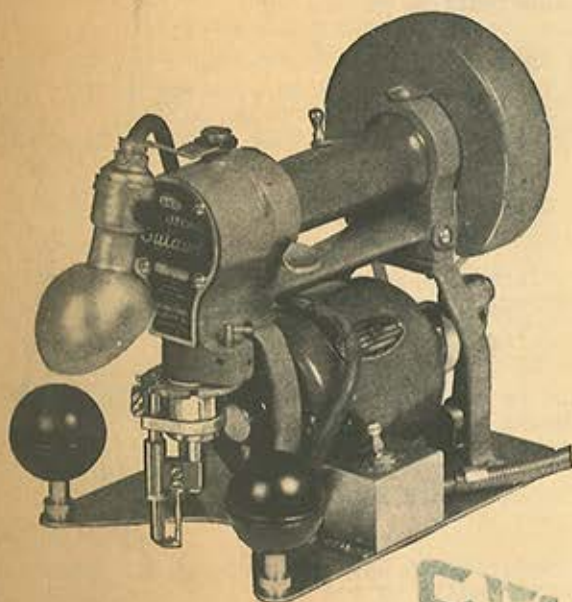

C.W. MARWEDER
ESTABLISHED 1878
TOOLS - METALS - SHOP SUPPLIES
7 1/2 First Street
SAN FRANCISCO
Duquesne 4180
11th & Alice Sts.
OAKLAND
Telephone 3600

Manufactured by

International Register Company

15 South Throop Street, Chicago, Illinois

INTRODUCTION

The K9 Cutawl and the K9A model which replaced it are practically alike. The only differences between them is in the guide tube, guide feet, chisel block and swivel which are heavier in the K9A than in the K9. In adjustment and operation the two machines are identical.

SETTING UP THE K9 AND K9A CUTAWL

The Cutawl is shipped assembled complete and ready for immediate use.

GENERAL INSTRUCTIONS

The Cutawl uses either a chisel or a saw. The chisel is for cutting thin layers of hard materials such as sheet metal or fibre, and soft materials to a maximum of 11/16 inch; the saw for cutting harder materials to a maximum of 1-1/4 inches. On page 4 is given a list of materials which can be cut with the Cutawl, the maximum thickness that can be handled and the best chisel or saw to use.

When using the chisel, the following four points MUST be given attention, otherwise the Cutawl will not operate properly.

1. Choice of the proper chisel for the particular material to be cut.
2. Correct setting of the stroke.
3. Accurate adjustment of the clearance.
4. Regular and adequate lubrication.

The proper chisel can be chosen by reference to the table on page 4. Setting of the stroke and clearance is described in paragraphs A5 and A6 respectively, while figure 11 on page 9 gives full details for lubricating the machine. Incorrect setting of the clearance accounts for more trouble than all other factors combined so that this point in particular needs attention.

OPERATION OF THE CUTAWL USING A CHISEL

Below is given detailed information on the most satisfactory type of table or bench on which to work; how to choose the correct chisel, stroke and clearance, and the best way to guide the Cutawl.

A1--BENCH. A bench should be provided on which to lay the material to be cut. For greatest comfort of the operator, it should be about 38 inches high, with a smooth wood top. It is best to have the top at least 1-3/4 inches thick to prevent undue vibration. Cover the bench with a sheet of wallboard or several layers of heavy cardboard nailed in place. This serves as an underlay for the work and prevents damage to the bench top and the chisels.

A2--MATERIAL. Place the material to be cut on top of the bench and fasten it down. This is easiest done by nailing with small nails or brads. For cutting very soft materials such as cloth or paper, or when cutting metal, follow the special instructions given in paragraphs A12 and A13 respectively.

A3--CHISELS. Different chisels are used for cutting different materials. The correct chisel for any material can be ascertained by reference to the table on page 4. In general, the following directions apply:

1. For soft materials such as wallboard, cardboard, etc., use the No. 24 chisel.
2. For hard materials such as stencil board and sheet fibre, use the No. 25 chisel.
3. For wood and metal, use the No. 22 chisel.

All chisels should be inserted far enough into the chisel block so that the upper end is flush with the top of the block. Place the flat side of the chisel shank against the set screws. Care must be used to see that the chisel blade is vertical, and also parallel with the sides of the chisel block, after the set screws are tightened. Otherwise the chisel will not cut properly. If the chisel is not vertical or parallel with the chisel block, bend it gently until it is in the proper position, or replace it with a new chisel.

The chisel AT ALL TIMES should be held between the leaves of the chisel guide. Saws do NOT require the guide foot. It MUST NOT be used with them. Do not let the chisel rise above or come out of the chisel guide at any time. Otherwise the guide will wear quickly and may be broken.

CHARACTERISTICS OF INDIVIDUAL CHISELS

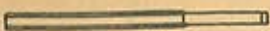
No. 3 CHISEL.  For cutting designs in soft materials, such as wallboard, cardboard, linoleum or felt. Maximum thickness it can cut is 1/4 inch. Use the chisel guide and high or low speed.

No. 5 CHISEL.  For cutting very intricate designs in soft materials, such as soft wood, cardboard, or wallboard, where a very narrow kerf or where accurate fitting inlays are wanted. Maximum thickness it can cut is 3/16 inch. Use high speed and the chisel guide. See paragraph A6 for special instructions regarding clearance.

No. 7 CHISEL.  For cutting from 1 inch minimum to 1-1/2 inches maximum of very soft materials, such as felt, cloth and tissue paper. The upper layers of material are cut with the knife edge without the chisel coming out of the work, while the lower layers are cut with the end.

To use, fasten down the work as directed in paragraphs A1 and A2. Set the stroke at a maximum of 3/4 inch and adjust the depth of the stroke (see CLEARANCE paragraph A6) until at the bottom the chisel cuts into the underlay 1/32 inch. Proceed as directed in paragraph A8 CUTTING.

Use on low speed only without the chisel guide.

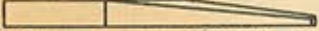
No. 11 CHISEL.  For cutting designs in soft materials such as wallboard and cardboard, where a very smooth cut is required. The maximum thickness it can cut is 5/8 inch. Use on low speed only, with the chisel guide.

No. 22 CHISEL.  For use in cutting sheet metal, wood, celluloid, very dense cardboard and all similar materials which tend to heat other chisels. The maximum thickness it can cut is 5/8 inch. Use on high and low speed with the chisel guide.

No. 24 CHISEL.  The preferred chisel for general cutting of all soft materials such as wallboard, cardboard, felt, cloth, etc., up to a maximum thickness of 11/16 inch. Use the chisel guide. With soft materials up to 3/8 inch in thickness, use high speed; for thicker layers use low speed only.

No. 25 CHISEL.  Preferred for general cutting of hard materials such as fibre, stencil board, etc., up to a maximum of 3/8 inch. Use high and low speed with the chisel guide.

The Nos. 0, 2, 6 and 8 chisels may be used with the K9 and K9A but are less satisfactory than those given above and consequently are not recommended. The maximum stroke on which the Nos. 0 and 8 chisels can be used is 1/2 inch; the maximum for the others is 3/8 inch. All can be used on high or low speed, always with the chisel guide.

CHISEL BREAKAGE

Chisel breakage is caused by

1. Using the wrong chisel for a particular material.
2. Trying to cut too much material at one time.
3. Using too long a stroke.
4. Allowing too much or too little clearance.
5. Using high speed when cutting too thick material.
6. Cutting abrasive materials. Some cheap wallboards contain gritty material which dull and ultimately cause chisels to break. Do not try to cut these wallboards.

CHISEL OVERHEATING

Overheating of a chisel which will ultimately cause it to break is caused by

1. Cutting too much material at one time. Do not exceed the maximum given in the table on page 4.
2. Using the wrong chisel. If other chisels burn, shift to the No. 22 or No. 25. These seldom overheat.
3. Employing too long a stroke. Always use the shortest stroke which will still cut through the material.
4. Running on high speed. Restrict the use of high speed to metal cutting and not more than 3/8 inch of wallboard, cardboard, or similar soft materials.
5. Moving the Cutawl so slowly that the chisel cuts in essentially the same place for some time. Move the Cutawl as fast as practicable if the chisel tends to heat.

MATERIALS CUT WITH THE K9 AND K9A CUTAWL USING EITHER CHISEL OR SAW

Material	Chisel Preferred Given First	SPEED High (H) Low (L)	Maximum Thickness which can be cut	SAW PREFERRED		Maximum Thickness Which Can be cut
				With Saw Table	Without Saw Table	
Aluminum sheet	22,25	H	1/16" (14 gauge)	14		1/8"
Asbestos, hard		L		14	13	3/8"
Asbestos, soft	25,24	L	1/2"			
Auditec.	24,11	H or L	5/8"			
Bakelite	25	H	1/16"	14	13	1/4"
Beaver Board	24,3,11	H or L	5/8"			
Brass sheet.	22,25	H	1/32" (20 gauge)	14		3/32"
Cardboard, soft.	24,3,11	H or L	11/16"			
Cardboard, hard.	25,22,24	H or L	5/16"	14	13	3/4"
Celluloid.	25	L	1/8"			
Celotex.	24,3,11	L	11/16"	14	13	1-3/8"
Cloth.	24,11	H or L	11/16"			
Cloth.	7	H or L	1" min. to 1 1/2" max.			
Compo Board.	22,24	L	1/2"	14	13	3/4"
Copper sheet	22,25	H	3/64" (17 gauge)	14		3/32"
Cork	24,11	L	11/16"	14	13	1-1/4"
Cornell Board.	24,11,3	H or L	5/8"			
Felt	24,11	H or L	11/16"			
Felt	7	H or L	1" min. to 1 1/2" max.			
Fibre sheet.	25,22	H	1/8"	14	13	3/8"
Homasote	24,11	H or L	11/16"	14	13	1-1/4"
Insulite	24,11	H or L	11/16"			
Iron, Galv	22,25	H	.022 (25 gauge)	14		1/16"
Lead sheet	22,25	H	1/4"	14		1/2"
Leather.	24,11	H or L	3/8"			
Linoleum	25,24,3	H or L	1/2"	14		3/4"
Masonite, soft	24,11,3	H	11/16"	14	13	1-1/4"
Masonite, hard	25	L	1/4"	14	13	3/4"
Metallic Foils	25,22	H	1/4"			
Mica	25	H	1/8"			
Paper, crepe	24,11,3	L	1/2"			
Paper, kraft	25	L	3/8"			
Paper, tissue.	24,11,3	L	1/2"			
Pressed Board.	25	H	5/16"			
Rubber sheet	24,11	L	1/2"	14		3/4"
Rubber, hard	25,22	L	1/16"	14	13	1/4"
Steel.	22	H	.022 (25 gauge)	14		1/16"
Steel, Galv. sheet	22	H	.022 (25 gauge)	14		1/16"
Stencil Board.	25	H	1/4"			
Upson Board.	24,11,3	H or L	5/8"			
Veneer, 3 ply, soft.	22,24,5	L	5/16"	14	13	1-1/4"
Veneer, 3 ply, hard.	22	L	1/4"	14	13	3/4"
Wallboard.	24,11,3,5	H or L	11/16"	14	13	1-1/4"
Wood, soft	22,24,5	L	1/2"	14	13	1-1/4"
Wood, hard	22	L	1/4"	14	13	5/8"
Zinc sheet	22,25	H	1/32" (13 gauge)	14		1/8"

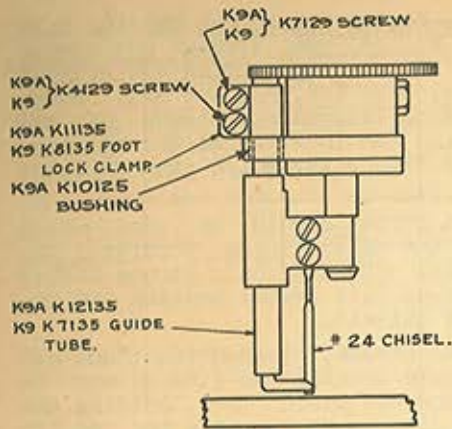

Figure 1

A4--CHISEL GUIDE. The chisel guide, which is illustrated in figure 1 supports the chisel just above the work and directs it so that each cut follows the path begun by its predecessors.

It is used with the Nos. 0, 2, 3, 5, 6, 8, 11, 22, 24 and 25 chisels only. It should NOT be used with the No. 7 chisel or with any type of saw. To do so would ruin the chisel guide.

TO USE THE CHISEL GUIDE.

1. Insert the blade of the chisel between the leaves of the guide and slip the chisel shank into the chisel block. Fasten the chisel in the chisel block by tightening both set screws MODERATELY.

2. Adjust the clearance (see paragraph A6 for directions) so that at the top of the stroke the cutting edge of the chisel is very slightly below the bottom of the guide foot. See figure 1. Follow these instructions exactly and the K9 and K9A Cutawl always will cut well.

CAUTIONS:

a. Do not allow the chisel to rise above and come out of the chisel guide at any time. To do so will injure the chisel guide.

b. Do not try to use chisels with short blades such as the Nos. 3, 5 or 25, on more than 3/8 inch stroke. On longer strokes, the broad shank of the chisel will spread the leaves of the guide apart, bending them and injuring the guide foot.

WHEN THE CHISEL GUIDE IS NOT USED

When the No. 7 chisel or any saw is being used, and the chisel guide, therefore, is NOT required, it should be swung to the "off" position illustrated in figure 2.

TO TURN THE CHISEL GUIDE TO THE "OFF" POSITION

1. Remove the chisel from the chisel block.
2. Raise the K13135 latch on the K9A, or the K9135 latch on the K9 (see figure 2) out of the notch.
3. Rotate the latch and chisel guide anti-clockwise as far as it will go. Release the latch. The chisel guide in the "off" position is completely out of the way of the chisel and will be held in this position by the latch.

TO REPLACE A WORN CHISEL GUIDE

If a chisel guide becomes worn, it is easily replaced by installing a K12135 (K7135) guide tube and chisel guide combination. (See figures 1 and 2). This is done by loosening the K4129 and K7129 (K4129) screws in the K11135 (K8135) clamp, pulling out the K12135 (K7135) guide tube and substituting a new one for it.

When installing the new guide tube and foot assembly make certain of the following points:

1. Be sure that the guide tube is PUSHED UP into the swivel as far as it will go so that the shoulder on the tube rests firmly against the swivel.
2. Also see that the foot lock clamp is PUSHED DOWN until it presses firmly against the swivel. This is necessary to prevent the guide tube moving up and down and becoming worn.
3. Before tightening the K4129 and K7129 (K4129) screws (see figures 1 and 2), which lock the guide tube in place, make certain that the guide foot is EXACTLY IN LINE with the chisel block. This is done as follows:
 - (a) Install a new straight chisel in the chisel block, (a No. 0 is convenient. The No. 24 is too long.)
 - (b) Slip the K13135 (K9135) foot latch into the slot in the swivel so that it is in the position shown in figure 1.
 - (c) Turn the K12135 (K7135) guide tube until the cutting edge of the chisel is exactly between the leaves of the foot.
 - (d) Tighten the K4129 and K7129 (K4129) screws VERY firmly.

When these screws are tight the chisel guide should have no up and down play. This, and having the chisel come EXACTLY between the guide foot leaves, are absolutely necessary if the Cutawl is to operate properly.

If there is play between the K12135 (K7135) guide foot where it passes through the K9125 (K6125) swivel, poor cutting may result. On the K9A this play can be eliminated by driving out the K10125 swivel bushing on which all wear is concentrated and replacing it with a new bushing. On the K9 Cutawl no bushing is provided so that the entire K6125 swivel must be replaced if wear has occurred.

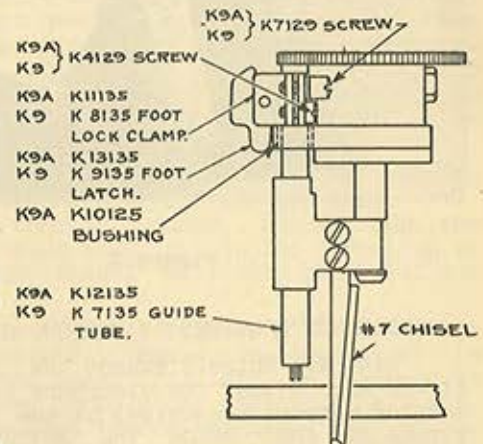

Figure 2

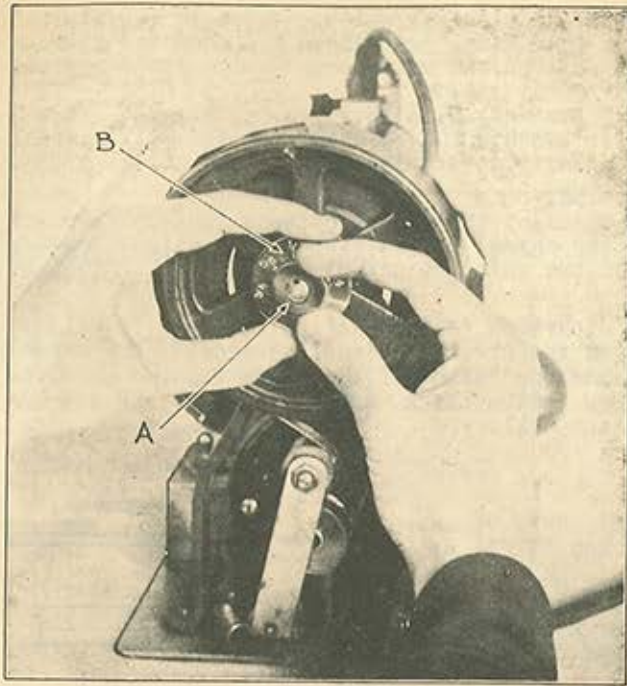

Figure 3

CLEARANCE REQUIRED BY VARIOUS CHISELS

With all chisels except the Nos. 5, 7, 11 and 22, adjust the clearance so that the cutting edge of the chisel at the top of the stroke IS JUST BELOW THE BOTTOM OF THE CHISEL GUIDE, as shown in figure 1.

With the No. 5 chisel adjust the clearance so that the chisel at the top of the stroke just comes out of the work. If more clearance is allowed the chisel will jump when turning corners.

With the No. 7 chisel, see directions on page 3 under the heading "No. 7 Chisel".

With the Nos. 11 and 22 chisels, adjust the clearance so that at the top of the stroke the tip of the chisel remains 1/16 inch in the material being cut, as shown in figure 10. To have the tip of the Nos. 11 and 22 chisels come out of the work reduces their efficiency.

A7--HIGH AND LOW SPEED. The Cutawl may be driven at either of two speeds. The speed is changed by installing a large or small pulley on the motor shaft. With the large pulley in place the chisel operates at high speed which is about 3400 strokes per minute; with the small pulley installed low speed is obtained which is about 2100 strokes per minute.

LOW SPEED is to be used whenever the material being cut exceeds 3/8 inch or when the chisel heats excessively. It is always to be used in cutting three layers of wallboard.

HIGH SPEED is for cutting hard and brittle materials such as sheet metal, stencil board and fibre, or for thin layers of soft materials such as 1. layer of wallboard, 1/4 inch of cardboard or 3/16 inch of wood.

A5--STROKE. On the hub of the driving pulley (see figure 3) is the stroke adjustment mechanism. On the adjustment disc are stamped the fractions 1/4, 3/8, 1/2, 5/8 and 3/4, which indicate the various lengths of stroke of the chisel in inches. The location of the red tipped pin shows the stroke for which the machine is set.

The shortest stroke should be used which will cut through the material and provide the required clearance. Do not use a stroke longer than is necessary as this causes heating and unnecessary wear on chisels.

To adjust the stroke, loosen the thumb nut A as shown in figure 3 until the disc B can be disengaged from the red pin. Then, holding the pulley, turn the disc so as to place the red pin in the hole opposite the stroke wanted. Tighten the thumb screw firmly.

A6--CLEARANCE. The clearance or the amount the chisel comes out of the work at the top of the stroke, must be correctly adjusted or the Cutawl will not operate properly and may even be seriously damaged. The clearance must be reset whenever the stroke is altered or a chisel changed.

To adjust the clearance turn the pulley wheel until the chisel is in its uppermost position. Then loosen the thumb screw C, figure 4, and turn the shaft housing using the knob D until the proper clearance is obtained. Tighten the screw C and the machine is ready to cut.

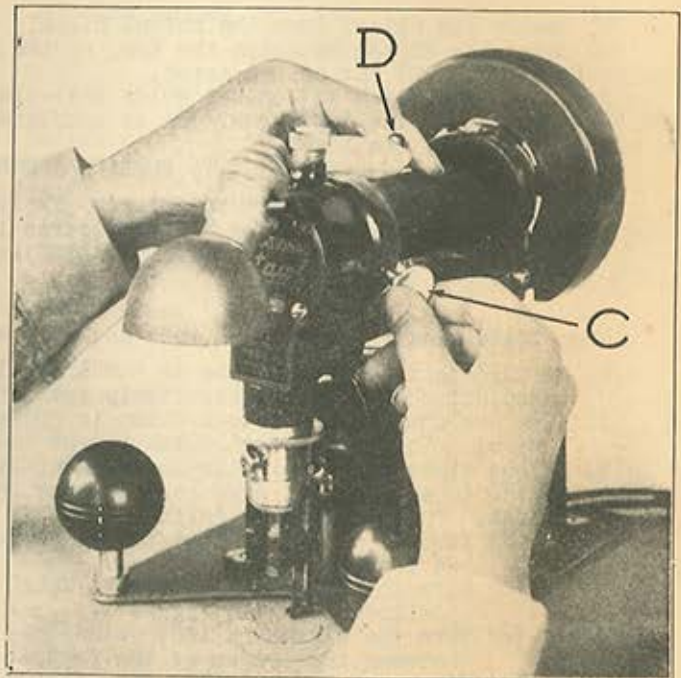

Figure 4

Cutting two layers of wallboard on high speed will cause excessive heating of the chisels unless the Cutawl is kept moving rapidly.

TO INSTALL THE HIGH SPEED PULLEY

The high speed pulley is normally kept on a lug fastened to the left rear leg. It is held in place by a spring catch. To remove, merely pull it off the stud. To remount, slip the round hole in the end of the pulley over the stud and push it on as far as it will go. The low speed pulley is removed and mounted similarly.

To install the high or low speed pulley on the motor shaft, first remove whichever pulley is in place. This is done by turning the lock screw in the motor sleeve in an anti-clockwise direction until loose. Then lift the idler arm out of the way, remove the belt and pull the pulley off the motor shaft. Slip the round end of the hole in the new pulley over the shaft pushing it on as far as it will go. Make sure the flat portions of the sleeve and pulley correspond. Lock the pulley in place by turning the lock screw in a clockwise direction until tight. Put the belt in place and let the idler pulley rest against it to maintain tension.



Figure 5

but neither the work nor the Cutawl itself has been rotated. The chisel and cutting mechanism do all the turning.

A8--CUTTING. Place the machine on the work and connect the motor cord to any lamp outlet of 110 to 120 volt direct or alternating current. Grasp the ball handles as shown in figure 5. Tilt the machine back so that the chisel clears the work. Turn on the switch with a finger of the right hand as shown in figure 5. Take hold of the swivel by the knurled disc using the thumb and forefinger of the left hand. Turn the swivel until the now swiftly moving chisel points in the direction in which it is desired to cut. Then, still holding the knurled disc with the fingers, insert the moving chisel at the desired place.

As soon as the chisel is in the work, release the knurled disc and guide the machine by holding the ball handles ONLY.

When changing direction or turning corners, DO NOT turn the whole machine. Merely push, without turning, in the direction in which it is desired to cut. The chisel will turn of itself and cut in the direction wanted.

The action of the machine is shown in figures 6, 7 and 8. In figure 6 the chisel is cutting directly towards the operator; in figure 7 it is cutting towards the operator's left; in figure 8 it is cutting away from the operator, completing the end of a U cut. The chisel and cutting mechanism have turned through a half circle

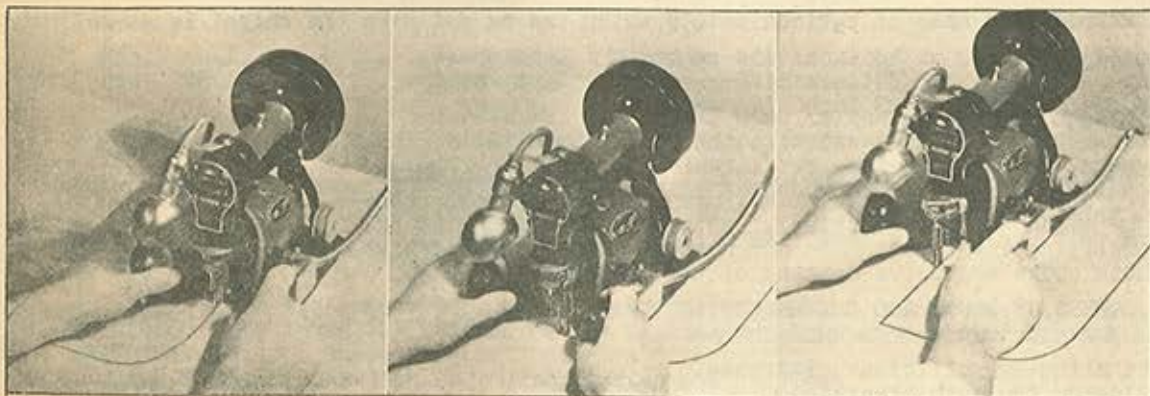

Figure 6--Cutawl cutting toward the operator. Neither work nor Cutawl is turned.

Figure 7--Cutawl cutting toward the operator's left. The cutting mechanism alone does the turning.

Figure 8--Cutawl cutting away from the operator.

At the end of any cut, turn off the switch and tilt the machine back until it rests in a vertical position on the pulley guard. Do not let it rest on the chisel. To do so will dull and bend it.

A9--SWIVEL BRAKE. For most satisfactory cutting the swivel mechanism should not turn too easily but should always exert a slight uniform drag on the chisel. The necessary resistance to turning is provided by the K7125 swivel brake (figure 22 or 23). The brake is set at the factory and should not be adjusted or touched.

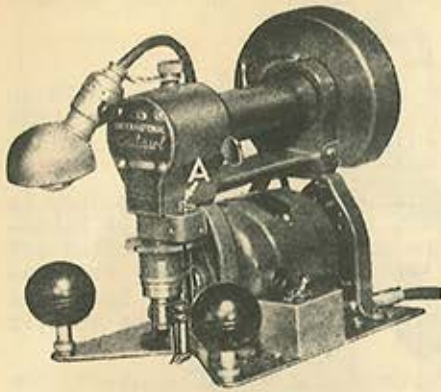

Figure 9

A10--SWIVEL LOCK. The Cutawl is provided with a swivel lock to facilitate the cutting of straight lines. To lock, turn the swivel until the proper notch in the knurled disc is directly under the swivel latch marked A in figure 9. Then push the swivel latch down until the end of the latch fits into the notch, locking the swivel. If the swivel latch lies against the Cutawl frame turn it outward so the fingers can grasp it for easy operation up or down.

To unlock the swivel, push the latch up until the swivel is free and the latch is caught and held by the automatic catch.

All--INSTRUCTIONS FOR CUTTING STRAIGHT LINES. To cut a straight line free hand with the Cutawl, rule the line on the work, lock the swivel (see paragraph A10) in the most convenient position and follow the line turning the ENTIRE MACHINE to correct any tendency to deviate.

Very accurate straight lines can be cut by laying a straight edge on the work and using it as a guide for the edge of the base plate.

A12--INSTRUCTIONS FOR CUTTING VERY SOFT MATERIALS. If the material to be cut is soft such as tissue paper, soft cloth, or felt, an overlay of stiff paper or cardboard should be placed upon it, and fastened through the material to the bench with small nails. This overlay holds down the edges of the material when cut and makes it easier to move the machine.

A13--INSTRUCTIONS FOR CUTTING SHEET METAL. The Cutawl will cut thin sheet metal very well using the chisel. The procedure given below has been found best. If carefully followed, excellent results are always obtained.

1. **UNDERLAY.** Use an underlay of wood or wallboard.
2. **FASTENING.** The metal and underlay should be tacked down or otherwise fastened very firmly to the table to reduce the tendency to vibrate.
3. **CHISELS.** For very thin metal when cutting fine designs use the No. 25 chisel; otherwise the No. 22.
4. **STROKE.** Set on 1/4 inch.
5. **CLEARANCE.** With the No. 25 chisel, adjust the clearance so that the cutting edge of the chisel at the top of the stroke is just below the bottom of the chisel guide. When using the No. 22, adjust the clearance so that the lowest tooth is just level with the bottom of the chisel guide as shown in figure 10.
6. **SPEED.** Use high speed.
7. **CUTTING.** In starting the cut the swiveling mechanism should be held firmly between the thumb and forefinger of the left hand so that it will not dance about as the chisel is being inserted. Otherwise, cutting is as described in paragraph A8.

The maximum thickness of various metals which can be cut with the chisel is as follows:

Aluminum sheet	1/16 inch (14 gauge)	Lead sheet	1/4 inch
Brass sheet	1/32 inch (20 gauge)	Zinc sheet	1/32 inch (13 gauge)
Iron, Galv.022 inch (25 gauge)		

Thicker layers must be sawed with the saw and saw table.

A14--INSTRUCTIONS FOR CUTTING THREE LAYERS OF WALLBOARD. Three layers of standard 3/16 inch wallboard can be cut most conveniently by using the No. 24 chisel, setting the stroke at 5/8 inch and employing low speed. Do not use 3/4 inch stroke or high speed as both cause excessive heating of the chisels.

A15--CAUSES OF ROUGH AND UNEVEN CUTTING.

A cut with a rough edge may be caused by--

1. Not allowing sufficient clearance.
2. Allowing too much clearance.
3. A dull chisel.
4. Using the wrong chisel.

Jumping of the chisel, particularly on curves is caused by--

- A. Running the Cutawl too fast.
- B. Allowing too much clearance. (This is particularly true when using the No. 3 and 5 chisels.)
- C. A bent chisel.
- D. Having the chisel guide not in line with the chisel and chisel block. (See paragraph A4).
- E. A badly worn chisel guide, plunger shaft or chisel block.
- F. Having the swivel brake either too tight or too loose.
- G. Having play between the guide tube and swivel.

If worn parts are responsible, the Cutawl should be returned to the factory for repairs.

A16--LUBRICATION. Because of the high speed at which the Cutawl operates, all moving parts always must be kept well lubricated. Reservoirs are provided from which lubricant is fed by wicks at a slow uniform rate to the bearings. Only K9 Cutawl Lubricant and Cutawl Oil should be used.

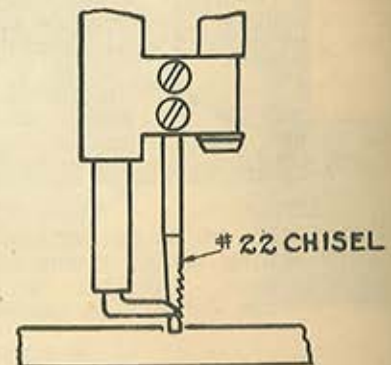

Figure 10

These are special products which will feed indefinitely through wicks without clogging--USE NO OTHERS. The Cutawl Lubricant formerly furnished should be used on K6, K7 and K8 Cutawls ONLY.

Figure 11 shows all points requiring lubrication. Use Cutawl Oil for the chisel guide tube C; use K9 Cutawl Lubricant for all other bearings. Motor bearings should be lubricated once a month. ALL OTHER BEARINGS MUST BE OILED DAILY. This is absolutely necessary.

DETAILED LUBRICATION INSTRUCTIONS

PLUNGER SHAFT. The plunger shaft is lubricated by a wick which is held against the shaft by a spring and draws lubricant from the reservoir A. The reservoir is filled by removing the cap. Use K9 Cutawl lubricant only. Fill daily.

CHISEL BLOCK BEARINGS. The chisel block bearing H is lubricated by a wick drawing oil from the hollow chisel guide tube C. FILL ONCE A DAY OR OFTENER, using only Cutawl Oil. Keep the dust cover in place to prevent dirt plugging the wick feed.

BELT IDLER. Lubricate by screwing down the screw plug F half a turn every day. This forces lubricant into the ball bearings as long as any remains in the tube G. When the plug F is screwed down as far as it will go, remove the plug and refill the tube with K9 Cutawl Lubricant. A wick in the tube G helps to maintain a slow even flow.

ENCLOSED MECHANISM. The crank pin, connecting rod bearings, etc., are self lubricated from excess lubricant thrown off by the plunger shaft. It is, therefore, of vital importance to keep the reservoir A full at all times.

Lubricant tends to escape around the drive shaft between the large pulley and the rear end of the frame. A packing is provided to prevent leakage. If leakage starts, the packing may be tightened as follows:

Remove nut A and disc B, figure 12, and insert wrench C in the hole in pulley D. Push lightly on wrench C and revolve the pulley until the wrench enters the hole in the packing nut E. Then, holding the wrench in position, turn the pulley in the same direction as it is driven by the motor, until the packing is tight.

CAUTION:

To avoid excessive wear and load on the motor, tighten the packing only enough to prevent leakage of lubricant.

MOTORS. The motors used on the Cutawl are specially built for this service. The only attention they require is regular lubrication and occasional replacement of the brushes. In ordering brushes, be sure to give the MOTOR as well as the CUTAWL NUMBER. For all other replacements or repairs, the motor should be returned to the factory. Satisfactory repair work on Cutawl motors ordinarily cannot be done by the average electrical repair shop. Keeping the motor free from dust and oil will increase its life appreciably.

The bushings in which the motor shaft runs, are made of special porous bearing metal. The wicks from the grease cups touch the outside of the bushing and lubricant passes through the bushing to the shaft as needed. There is no hole in the bushing to permit the wick to touch the shaft. This type of bearing has been thoroughly tested and has been found very satisfactory.

LAMPS. The electric lamps provided with the Cutawl are specially made to withstand severe vibration. Ordinary lamps will not last. Lamps always should be kept screwed in tightly as otherwise arcing will occur which will burn out the lamp socket.

CUTAWL USED AS A SAW

The Cutawl can be used as a saw by replacing the chisel with a saw blade. When used in this way it takes the place of a band or scroll saw. It possesses the distinct advantage over all other sawing tools of having the cutting mechanism swivel mounted so that in cutting curves or turning corners neither work nor machine need be rotated.

The illustrations show two methods of sawing with the Cutawl. In figure 13, page 10 the machine is used without attachments, the work being raised on parallel bars to allow clearance for the saw below. In figures 14 and 15, pages 10 and 11 the Cutawl is shown inverted and clamped in a specially designed saw table which may be used with legs (figure 14), or mounted without legs flush with the bench top (figure 15).

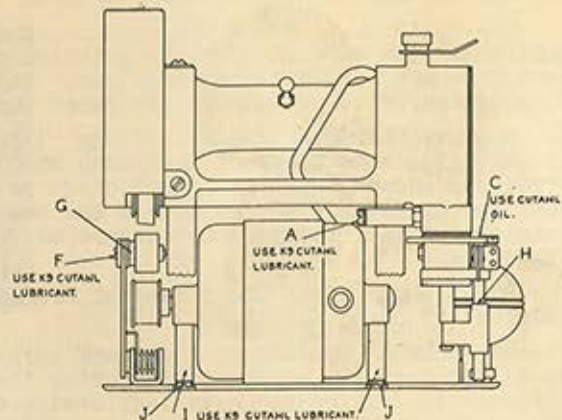

Figure 11

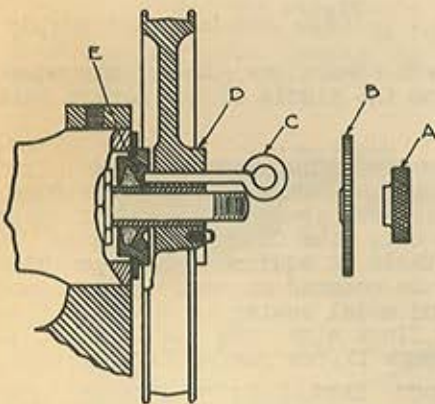

Figure 12

OPERATION WITHOUT THE SAW TABLE

B1--MATERIAL. Place the work to be saved on parallel strips of wood or other material of sufficient thickness so that the saw blade, at its lowest position, will not strike the bench top.

B2--SAW BLADES. The No. 13 Saw (see figure 21, page 12) is to be used. The shank should be inserted far enough into the chisel block so that the upper end is flush with the top of the block. The teeth should face toward the plunger as shown in figure 13.

B3--STROKE. Set the stroke at $\frac{3}{4}$ inch, as described in paragraph A5.

B4--CLEARANCE. Loosen the thumb screw C (figure 4) and turn the shaft housing using the knob D as far as it will go in an anti-clockwise direction viewing the machine from the front. This puts the plunger as close to the work as possible and permits cutting the maximum thickness of material. Lock the shaft housing in place by tightening the screw C.

B5--CHISEL GUIDE. When sawing with the Cutawl, the chisel guide is not required and should be swung out of the way as described in paragraph A4.

B6--SPEED. Use high speed wherever the saw does not heat and cuts smoothly. Otherwise use low speed.

B7--SAWING. Place the Cutawl on the material with the saw teeth toward the edge of the work and saw as when cutting with the chisel. When starting to saw from the middle of the work a hole must first be drilled in which to insert the saw.

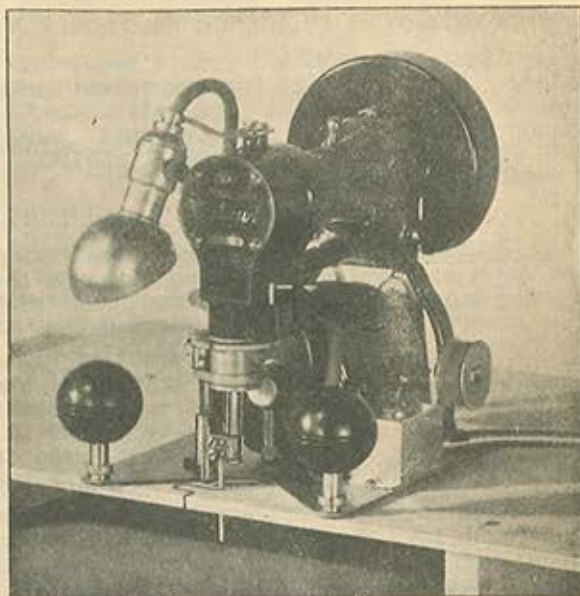

Figure 13

SAW TABLE

Where there is considerable sawing to be done, especially on fragile work or where metals or hard materials are to be cut, the Cutawl Saw Table is recommended. This table is equipped with removable legs so that it may be mounted on top of a bench for small pattern and model sawing as shown in figure 14, or mounted flush with the table top as shown in figure 15 page 11, for sawing large pieces.

SAW TABLE WITHOUT LEGS. To mount the saw table in a bench for use without legs, saw a $12\text{-}\frac{7}{8}$ inch square hole in the bench top. Center the saw table over this hole, with the side which has the spring latch toward the operator, and fasten it to the bench top by four wood screws through the holes around the edge of the saw table. This method of mounting leaves the saw table $\frac{1}{8}$ inch above the bench top. If it is desired to have it exactly flush, mark the outline of the saw table on the bench top and chisel out the wood between this line and the hole to a depth of $\frac{1}{8}$ inch.

SAW TABLE WITH LEGS. When used with legs, the saw table may be fastened to the bench top in any desired location. Assemble legs and top by pushing the grooved ends of the legs into their sockets in the saw table, being sure that they are in up to the shoulder.

Lock them in this position by tightening the set screws with a screwdriver. Fasten the legs to the bench top by wood screws through the holes in the feet. Have the side of the table on which the latch is located toward the operator so that the Cutawl can be fastened in place or unfastened easily.

OPERATION WITH THE SAW TABLE

C1--CHISEL GUIDE. Swing the chisel guide to the "off" position. See paragraph A4.

C2--SAW TABLE. With the saw table use the No. 14 saw. (See figure 21) Insert the saw blade in the holder as described in paragraph B2.

CAUTION:

Do not use the No. 13 saw blade, which is for use without the saw table.

C3--STROKE. Set at $\frac{3}{4}$ inch, as described in paragraph A5.

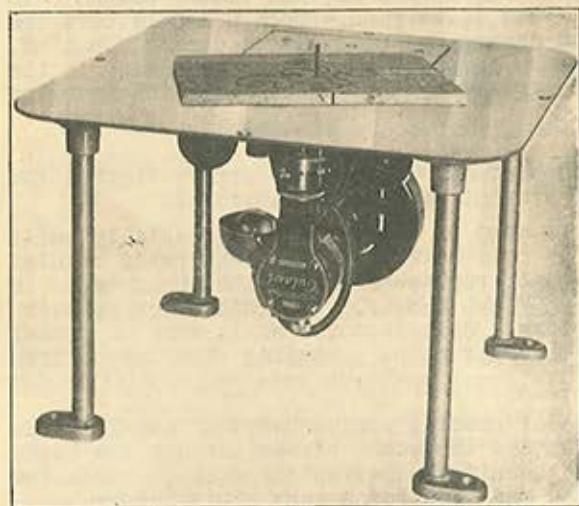

Figure 14

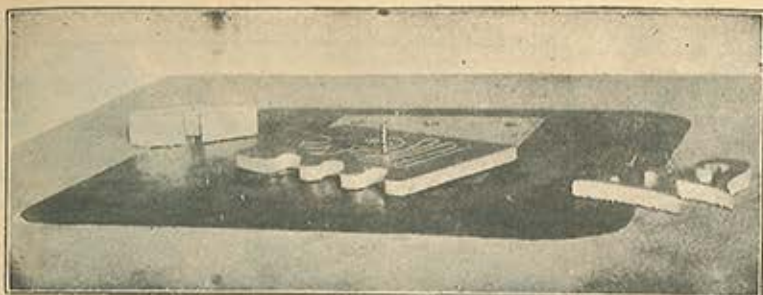

Figure 15

latch forward to clear the front tips of the base plate. See that the latch drops back into the grooves in the ball handle studs. This locks the Cutawl in position ready for use.

C7--SAWING. Place the work to be cut on the saw table, turn on the current and holding the work down with both hands, slide it over the table until it is in contact with the cutting edge of the saw. Unless the cut is started at one edge of the work a hole must be drilled from which to begin.

To guide the cutting DO NOT turn the work, merely push it in the direction in which it is desired to cut. The saw will turn and cut as the work is pushed against it.

The action of the Cutawl when used as a saw mounted in the saw table is shown below in figures 16, 17 and 18. In figure 16, the saw is cutting directly towards the operator; in figure 17 it has turned and is cutting towards the operator's right; in figure 18 it is cutting directly away from the operator, completing the end of a "U" cut. The work is not rotated. The saw does all the turning.



Figure 16--Cutting toward the operator. Unnecessary to turn the work.

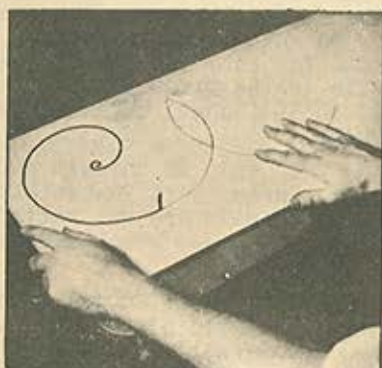

Figure 17--Cutting to the operator's right. The saw does the turning.

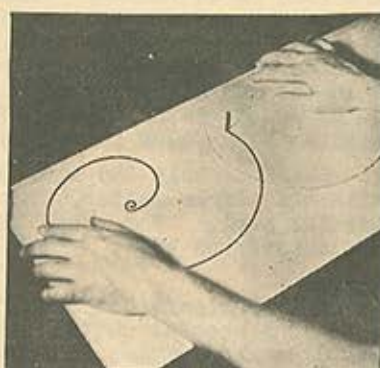

Figure 18--Cutting away from the operator; completing the curve.

The following precautions should be observed:

1. The harder the material the more firmly it must be held down against the saw table.
2. Do not force the material against the saw any faster than it will cut easily.
3. Do not move the material suddenly at right angles to the line of cut, but allow the saw to cut itself free in making all turns.

In sawing thin metal or other hard materials where its strength is not sufficient to stand the strain without bending or catching between the teeth and moving up and down with the saw, the material should be placed on or between layers of thin wood such as 3/16 inch thick three-ply veneer. It is usually necessary to fasten metal and wood layers together, as any movement between the several layers will cause saw breakage.

C8--LUBRICATION. When sawing with the Cutawl inverted in the saw table, sawdust tends to collect on top of the chisel guide and plunger bearings, absorbing the lubricant. This dust should be cleaned off every half hour and a few drops of Cutawl Oil dropped on the plunger and chisel guide shafts. The chisel block bearings, where it fits around the plunger, should also be cleaned at regular intervals and lubricated with Cutawl Oil.

CIRCLE CUTTING ATTACHMENT

There are two types of Circle Cutters. One can be used on K6, K7 and K8 Cutawls, but not on K9 and K9A; the other can be used on K9 and K9A machines but not on earlier models. Circle Cutters for K6, K7 and K8 Cutawls can be converted for use on K9 and K9A machines, but those built for use on K9 and K9A Cutawls cannot be fitted for use on earlier models.

E1--DESCRIPTION. The Circle Cutter is an attachment which fits on the front of the K9 and K9A Cutawl and guides it so that the chisel cuts a true circle. (See figure 19).

The attachment may be quickly fastened to the two ball handle studs. It has a removable slide carrying a pivot pin which may be adjusted so that circles from 3/4 inch to 48 inches in diameter may be cut.

E2--TO ATTACH. First lock the swivel as instructed in paragraph A10 so that the chisel cuts to the operator's right. Then hook the slot in the right side of the circle cutting attachment over the ball handle stud A as shown in figure 20. With the stud A acting as a pivot, swing the attachment to the left as indicated by the arrow, until the notch D is engaged with the ball handle stud E. Remove the ball handle from the stud E and drop the lock sleeve F over this stud so that the large end of the sleeve engages the circular depression of the notch D. Lock the attachment in place by screwing the ball handle down firmly.

E3--TO SET SIZE. To cut a circle of any desired diameter from 3/4 inch to 48 inches, loosen the two thumb screws G, figure 20, and move the adjustable slide H until the arrow on it is opposite the desired size on the scale. This scale is marked in 1/4 inch divisions from 1/2 inch to 48 inches. When the pivot pin in the adjustable slide is in the end nearest to the chisel the slide can be set for circles from 3/4 inch to 24 inches. To cut larger circles, remove the thumb screws, reverse the slide end for end, and insert the thumb screws in the end of the slide opposite to the pivot pin. The slide may now be set to cut circles from 24 to 48 inches. When the size is set, tighten both thumb screws securely.

E5--CHISEL. Only the Nos. 0, 3, 24 and 25 chisels should be used with the circle cutter, the first three soft materials, the last one for hard. The Nos. 11 and 22 chisels are not satisfactory and should never be used.

IMPORTANT:

We offer the services of our engineers free to Cutawl users to aid in solving special cutting problems. If you need help, send us complete data and samples if possible, and we will advise you promptly. When writing the factory concerning your Cutawl, or in ordering parts, be sure and give both the MODEL and SERIAL numbers.

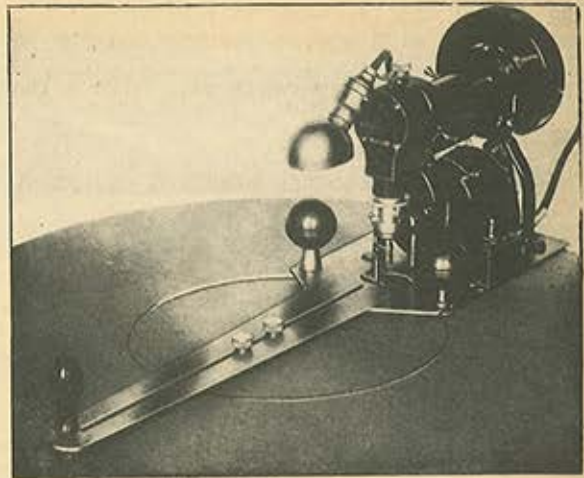

Figure 19

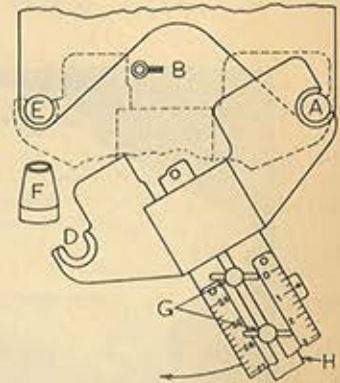

Figure 20

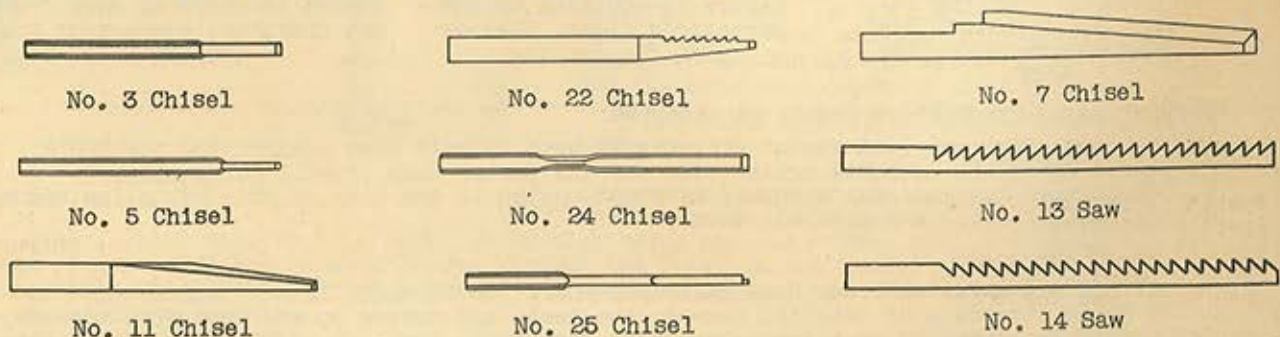

Figure 21

STANDARD EQUIPMENT

Subject to change without notice

The Standard equipment of each model K9 and K9A Cutawl is as follows:

6 No. 3 Chisels	6 No. 25 Chisels	2 K4129 Screws	1 Can Oil
6 No. 11 Chisels	6 No. 13 Saw Blades	1 Screwdriver	1 Special S11 Carbon Lamp
12 No. 24 Chisels	1 K251 Key	1 Tube Lubricant	Instructions

PRICE:

K9A Cutawl with 110-120 volt Universal Motor and Standard Equipment . . . \$125.00 f.o.b. Chicago.
 K9A Cutawl with 220-230 volt Universal Motor and Standard Equipment . . . 130.00 f.o.b. Chicago.
 K9A Cutawls with special motors and lights for voltages other than the above
 \$130.00 to \$140.00 f.o.b. Chicago,
 depending on voltage required. Give voltage wanted when ordering.

EXTRAS:

In addition to the standard equipment we furnish the following accessories:

Circle Cutter, complete for K6, K7, K8, K9 and K9A Cutawls. Price . . . \$ 7.50 f.o.b. Chicago.
 Carrying Case, with handle and serviceable lock. Made of three ply basswood, covered with imitation grain leather and trimmed with metal corners. Fits any K6, K7, K8, K9 and K9A Cutawl. Price . . . \$ 5.00 f.o.b. Chicago.
 Saw Table, to fit K6, K7, K8, K9 and K9A Cutawls, complete with detachable legs and 12 No. 14 Saw Blades. Price . . . \$ 12.50 f.o.b. Chicago.

SUPPLIES

CHISELS	1 to 4 doz. per doz.	5 to 11 doz. per doz.	Gross Lots per doz.
No. 0, Specials, made of improved steel for heavy service cutting thin layers of soft materials	\$2.00	\$1.75	\$1.50
No. 0, for general cutting of thin layers of soft materials	1.00	1.00	.90
No. 3, for general cutting of fine designs in soft materials	1.50	1.25	1.00
No. 5, for cutting extremely intricate designs in soft materials, or where a very narrow kerf is required.	1.50	1.25	1.00
No. 6, with step cut end, for cutting thin layers of hard and brittle materials.	1.75	1.50	1.25
No. 7, special side cutting chisel for cloth only	4.00	3.75	3.50
No. 8, same as No. 0 except sharpened at 45° angle, for cutting fine designs in soft materials.	1.75	1.50	1.25
No. 11, knife edge chisel for general cutting of soft materials	2.50	2.25	2.00
No. 22, special saw chisel for cutting wood and metal.	2.50	2.25	2.00
No. 24, preferred for general cutting of soft materials.	1.50	1.25	1.00
No. 25, step cut for general cutting of hard materials	1.75	1.50	1.25

SAW BLADES

Nos. 13 and 14, made of high carbon steel. 2.00 1.75 1.50

ELECTRIC LAMPS

120 volt, 20 watt, special Cutawl lamps. Price, each. \$ 0.50
 On 200 to 250 volts, two 120 volt lamps are used in series with a double bracket.

BELTS, price each.40

CUTAWL LUBRICANT Price per tube25
 Price per pound can.75

CUTAWL OIL Price per can.25

MOTORS:

Special Universal Cutawl Motors, 110-115 Volt. 11.00
 Special Universal Cutawl Motors, 220-230 Volt. 13.00
 Special Universal Cutawl Motors, other voltages. Prices on request.
 Factory Rebuilt Universal Cutawl Motors, 110-115 Volt only 8.00
 When exchanged for motor requiring repairs 5.50

GUARANTEE

We guarantee the INTERNATIONAL CUTAWL against defects of material and workmanship for SIX MONTHS from date of shipment, and will replace or repair defective parts free of cost provided they are returned transportation charges paid to the factory at Chicago.

International Register Company

15 South Throop Street,

Chicago, Illinois

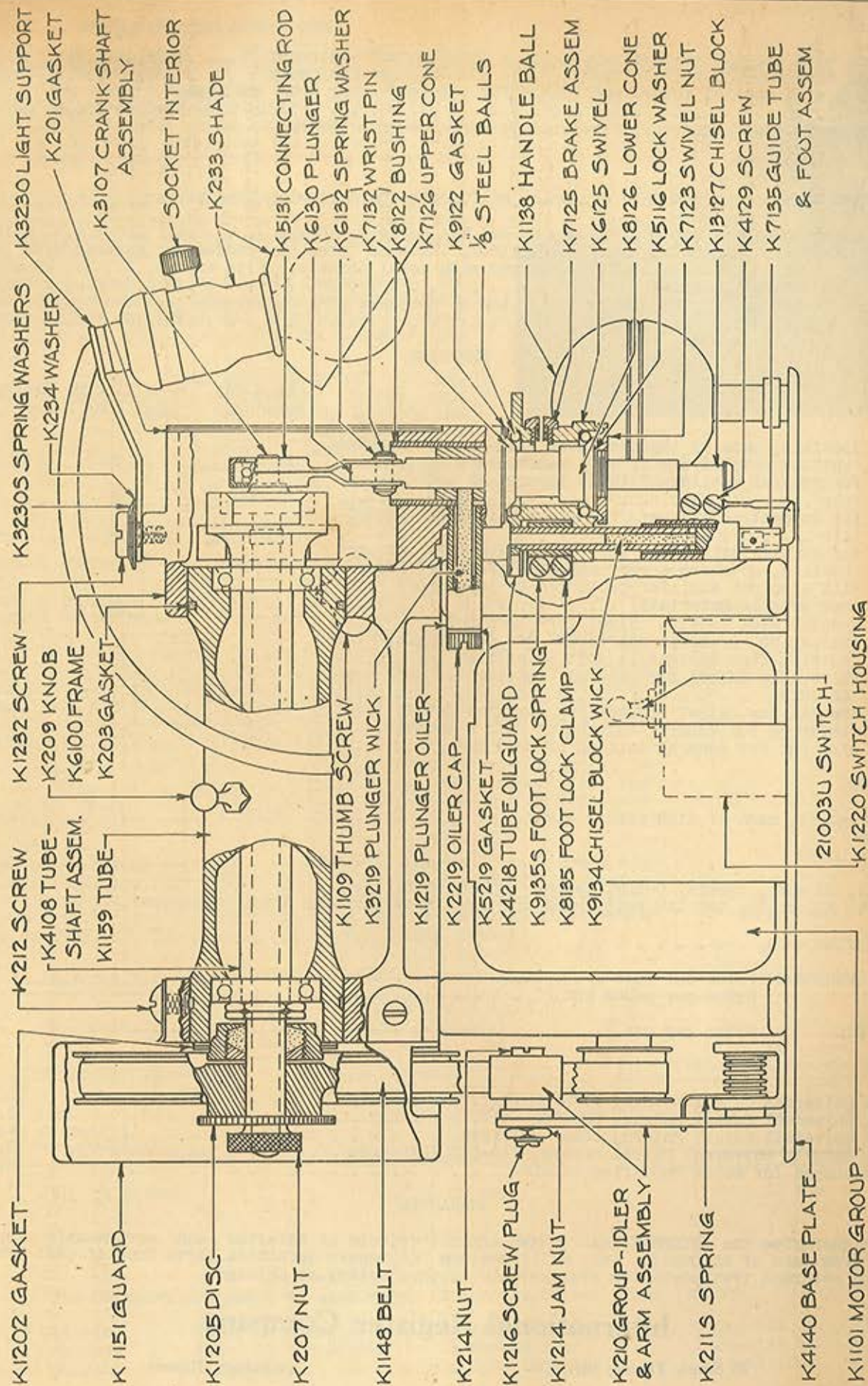

FIGURE 22 - K9 CUTAWL

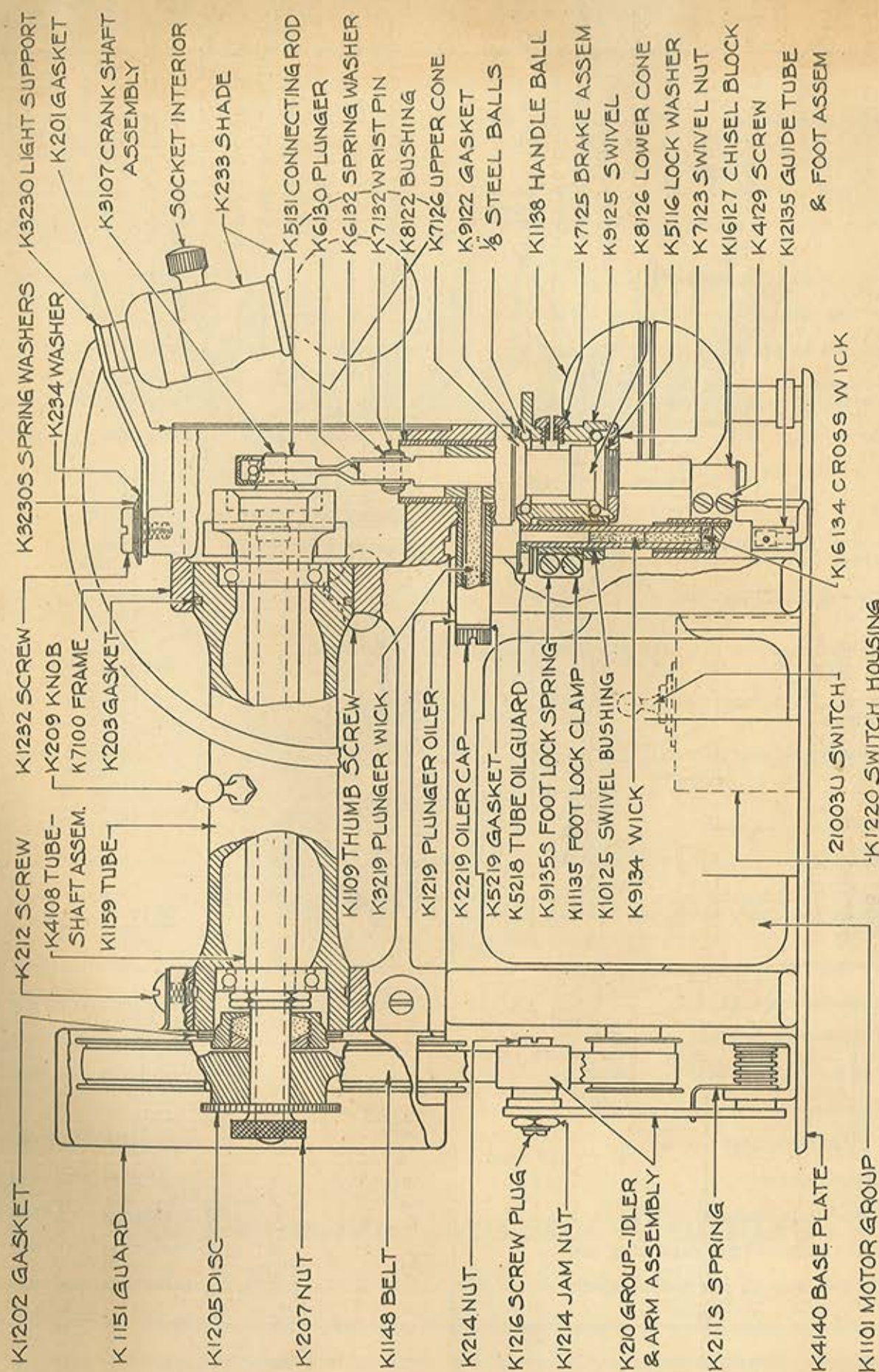

FIGURE 23 - K9A CUTAWL

INDEX

Chisel--Breakage, causes of	Page 3
Detailed discussion of various types.	Page 3
Diagrams showing different types.	Page 3 & 12
Operation of Cutawl with chisel	Page 2
Overheating, causes of.	Page 3
Prices.	Page 13
Proper chisel which should be used.	Paragraph A3, Page 2 and Table on Page 4
Chisel Guide--Complete information.	Paragraph A4, Page 5
Circle Cutting Attachment--Complete information	Page 12
Clearance--How to adjust.	Paragraph A6, Page 6
Cutting--Causes for rough and uneven cutting.	Paragraph A15, Page 8
Detailed instructions for cutting.	Paragraph A8, Page 7
Cutting Bench--Best type.	Paragraph A1, Page 2
General Instructions.	Page 2
Guarantee	Page 13
Lamps--General information.	Page 9
Prices	Page 13
Lubrication--General Instructions	Paragraph A 16, Page 8 and paragraph C8, Page 11
Materials--Which can be cut with the Cutawl and chisel or saw which should be used	Table on Page 4
Motors--General information	Page 9
Prices.	Page 13
Operation of Cutawl--With a chisel.	Page 2
With a saw	Page 9
With the Saw Table	Page 10
Parts Diagram	Pages 14 & 15
Prices--Accessories, chisels and supplies	Page 13
Saws--General information	Page 9
Maximum thickness which can be sawn	Table on Page 4
Prices.	Page 13
Saw Table--General information.	Page 10
Sheet Metal--How best to cut.	Paragraph A13 Page 8
Soft Materials--How best to cut	Paragraph A12 Page 8
Speed--When to use high and low speed	Paragraph A7, Page 6
Standard Equipment.	Page 12
Straight Lines--How best to cut	Paragraph A11 Page 8
Stroke--How to adjust	Paragraph A5, Page 6
Swivel Brake--Discussion of	Paragraph A9, Page 7
Swivel Lock--Instructions regarding use of.	Paragraph A10 Page 8
Wallboard--How best to cut three layers	Paragraph A14 Page 8